

| | | | | | | | | | |
|-----------|----|---------|----------------|---|-----------|------|---------------------|----------|----------|
| 8 | 7 | 6 | 5 | 4 | 3 | 2 | 1 | | |
| program # | op | machine | \$ EACH Qty. 2 | | REVISIONS | | | | |
| . | | lathe | | | ZONE | REV. | DESCRIPTION | DATE | APPROVED |
| | | | | | | A | UPDATED TOLERANCING | 2/8/2010 | DC |

| | | | | | | | | | |
|-----------|----|---------|----------------|---|-----------|------|---------------------|----------|----------|
| 8 | 7 | 6 | 5 | 4 | 3 | 2 | 1 | | |
| program # | op | machine | \$ EACH Qty. 2 | | REVISIONS | | | | |
| . | | lathe | | | ZONE | REV. | DESCRIPTION | DATE | APPROVED |
| | | | | | | A | UPDATED TOLERANCING | 2/8/2010 | DC |

| | | | | | | | | | |
|-----------|----|---------|----------------|---|-----------|------|---------------------|----------|----------|
| 8 | 7 | 6 | 5 | 4 | 3 | 2 | 1 | | |
| program # | op | machine | \$ EACH Qty. 2 | | REVISIONS | | | | |
| . | | lathe | | | ZONE | REV. | DESCRIPTION | DATE | APPROVED |
| | | | | | | A | UPDATED TOLERANCING | 2/8/2010 | DC |

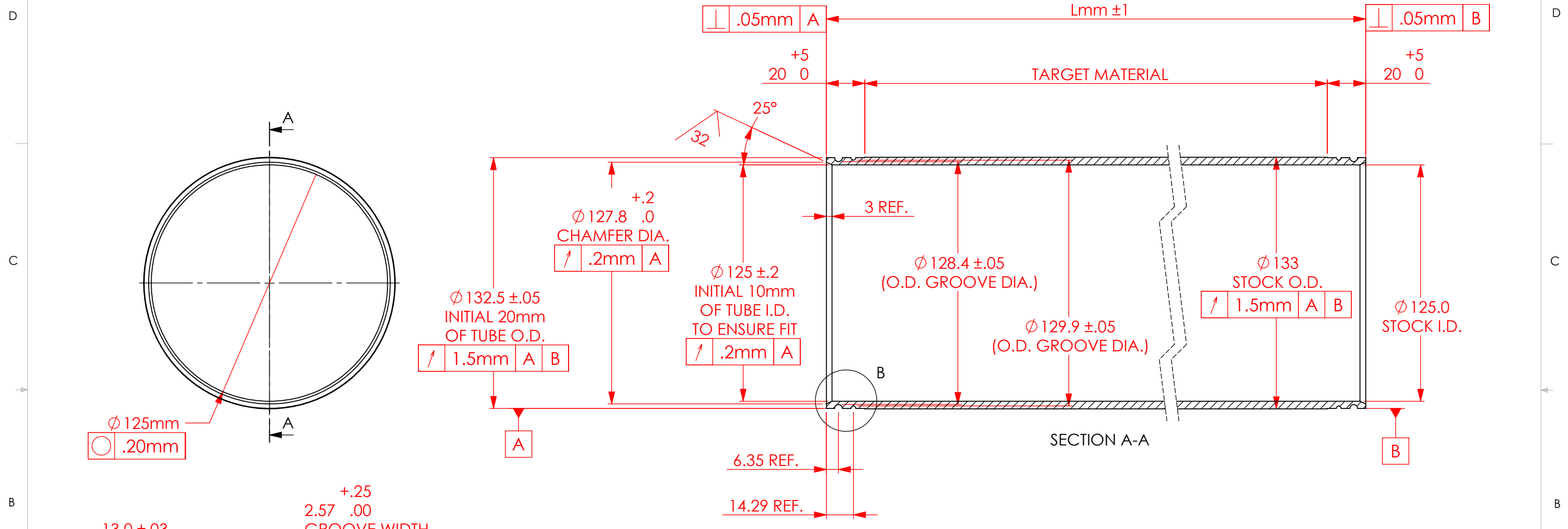

NOTE: DIMENSIONS ARE TYPICAL ON BOTH ENDS OF THE PART. FOR OUT OF ROUND TUBES, ENDS MUST BE BORED TO DIMENSION SHOWN.

- NOTES:**
1. BREAK AND DEBURR ALL EDGES .25mm MAX.
 2. CLEAN PART FOR USE IN A VACUUM ENVIRONMENT.
 3. PACKAGE PART TO PROTECT FROM DAMAGE AND TO ENSURE CLEANLINESS.

| | |
|--------------------------------------|--|
| UNLESS OTHERWISE SPECIFIED: | |
| X = ± 1 | |
| .X = ± .5 | |
| .XX = ± .25 | |
| .XXX = ± .125 | |
| INTERPRET GEOMETRIC TOLERANCING PER: | |
| WEIGHT | |
| DRAWN BY | |
| DO NOT SCALE DRAWING | |

| | | | | |
|-------------------------------------------------------------------------------------------|------------|----------|--------------|----------|
| SPUTTERING COMPONENTS, INC. 5625 BRISA STREET SUITE A LIVERMORE, CA 94550 | | | | |
| TITLE: SCI METRIC MANDREL FOR CANTILEVER | | | | |
| SIZE | DATE DRAWN | DWG. NO. | SCALE | REV |
| B | 8/28/09 | SCMC | 1:2 | A |
| MATERIAL: ALUMINUM | | FINISH: | SHEET 1 OF 1 | |