

Internal-Mount End Block TC-Series

Designed to replace planar cathodes where space is very limited on the ends, the TC-Series internal-mount end block provides performance in a compact package.

The TC end block is the most compact design available for standard 125 mm ID industrial targets but is a two-ended design.

Use it to upgrade from planar systems to increase the output and quality of your existing coater.

TECHNICAL SPECIFICATIONS

Electrical rating	▶ 40 kW 1500 V, 100 A (DC or 80 kHz AC)
Mounting	▶ Any orientation
Target	▶ 125 mm ID 1500 mm max. length
Maximum load	▶ 250 kg horizontal 100 kg vertical
Vacuum seal leak rate	▶ $<3 \times 10^{-7}$ mbar·L/s
Maintenance (typical)	▶ Seal kit and bushings every year (2 hr) Static seals, bearings and belt after 10 years (1 hr each side)



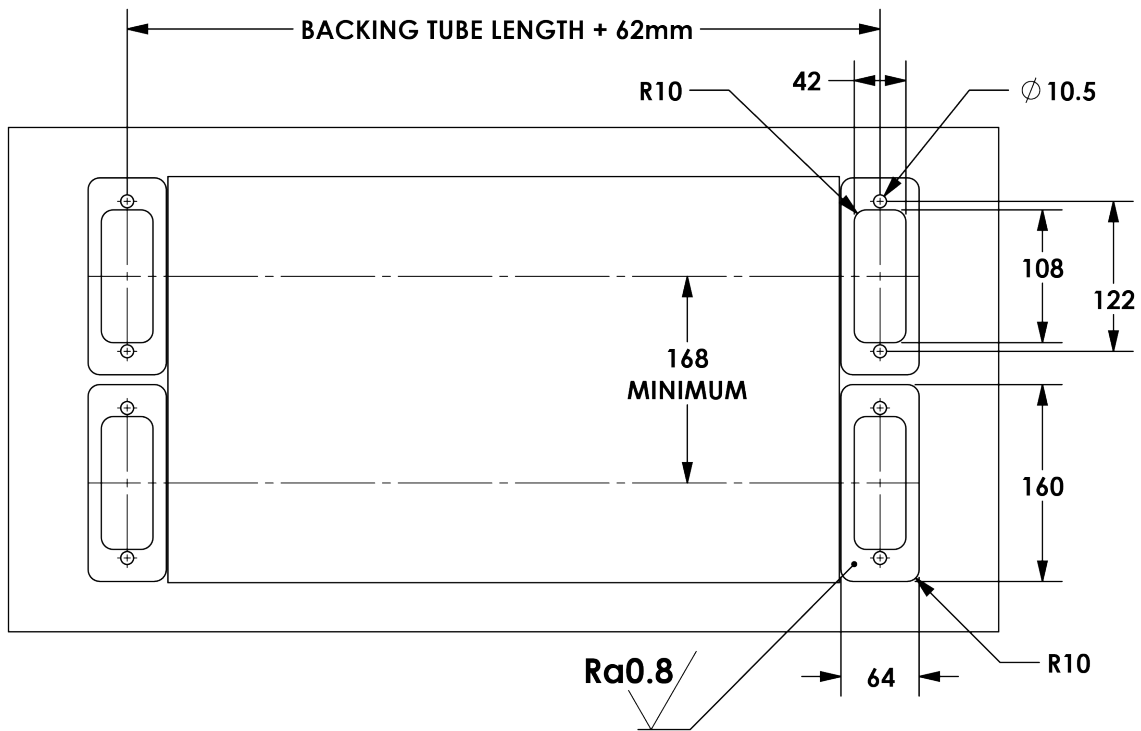
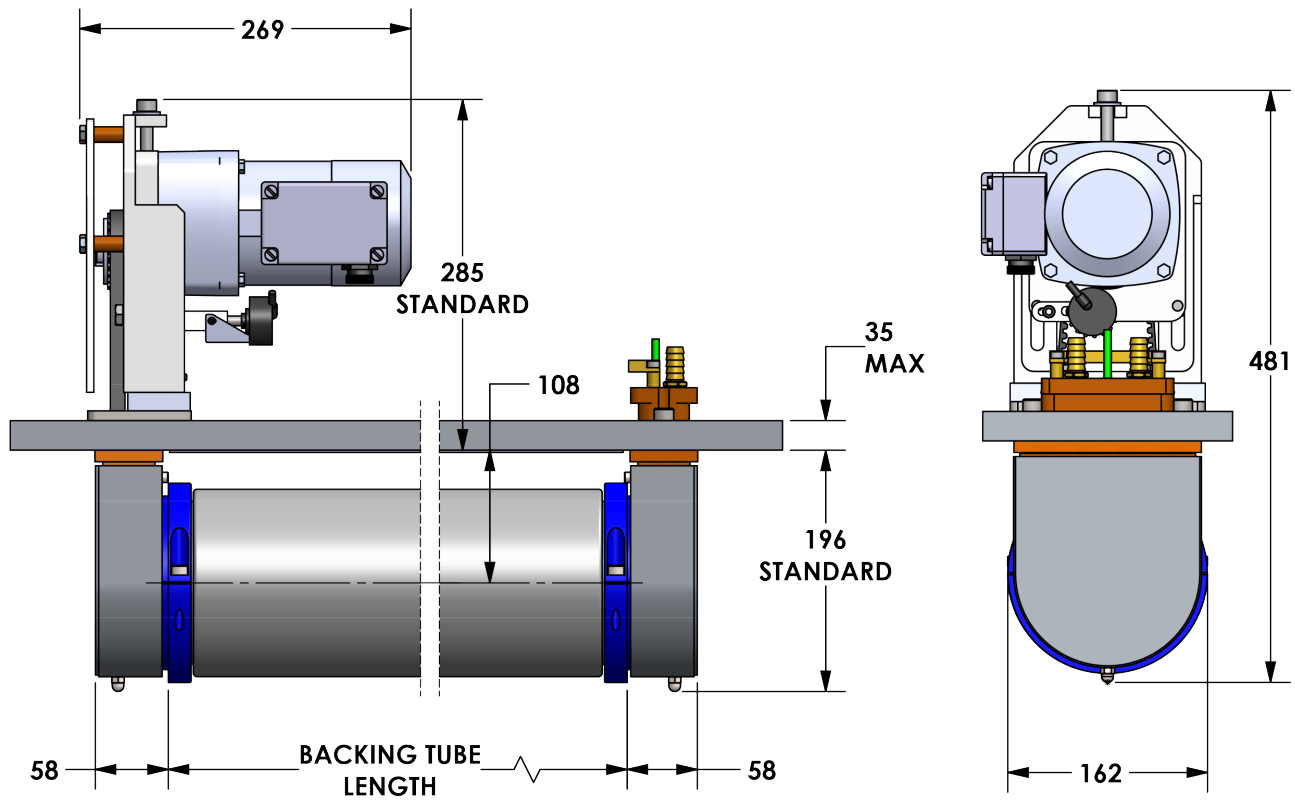

Dimensions in mm