

**SMALLEY RETAINING RING (108733, VHM-80-S02) IS TO BE PLACED INSIDE THE BOTTOM INTERNAL GROOVE TO KEEP THE MAGNET BAR INSIDE THE TARGET TUBE FOR VERTICAL TARGET CHANGE. GROOVE NOT REQUIRED IF HORIZONTAL TARGET CHANGE.**

REVISIONS			
REV.	DESCRIPTION	DATE	APPROVED

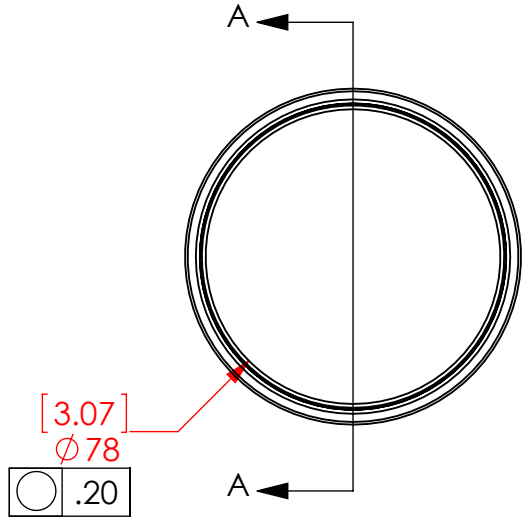

**NOTE: DIMENSIONS ARE TYPICAL ON BOTH ENDS OF THE PART.**

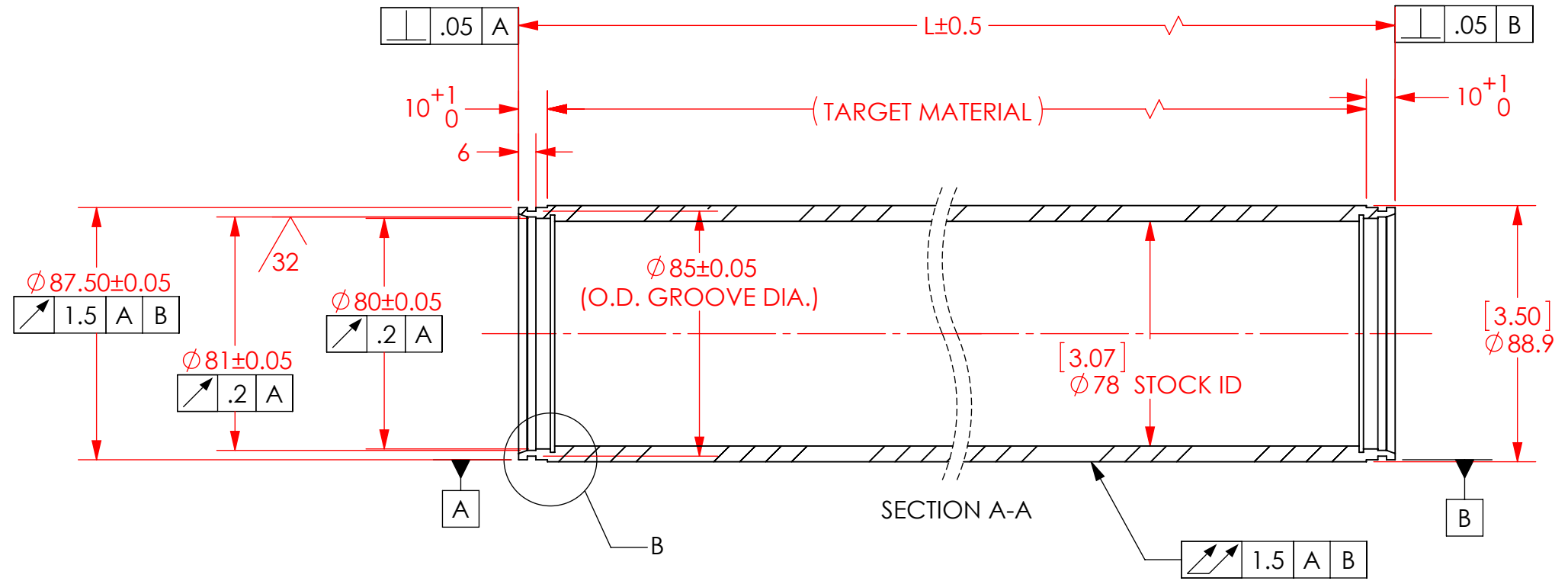
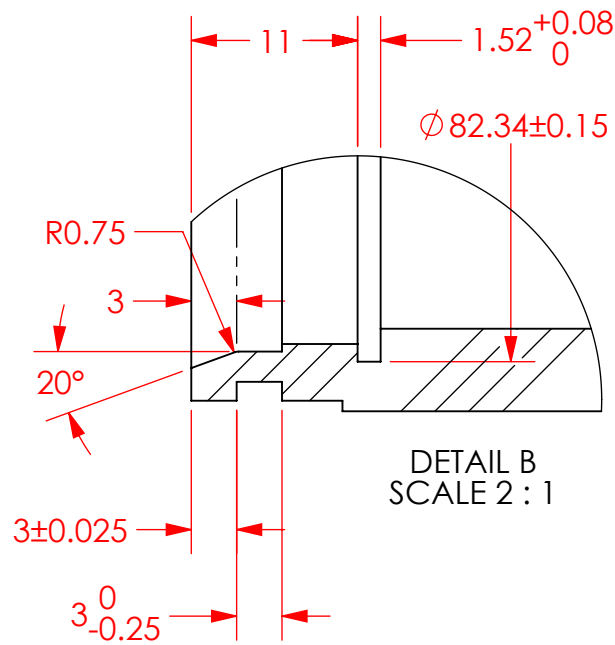

- NOTES:**
- BREAK AND DEBURR ALL EDGES .25mm MAX.
  - CLEAN PART FOR USE IN A VACUUM ENVIRONMENT.
  - PACKAGE PART TO PROTECT FROM DAMAGE AND TO ENSURE CLEANLINESS.

<b>UNLESS OTHERWISE SPECIFIED:</b>		<b>SPUTTERING COMPONENTS, INC.</b>				
<b>BREAK ALL CORNERS .015 Typ.</b>		375 Alexander Dr. SW, Owatonna, MN 55060				
imperial	metric	<b>CONFIDENTIAL:</b> UNAUTHORIZED USE, MANUFACTURE OR REPRODUCTION IN WHOLE OR IN PART IS PROHIBITED.				
X.0 = ± .030	X.0 = ± 1	<b>PROPRIETARY TO:</b> SPUTTERING COMPONENTS, INC.				
0.X = ± .015	0.X = ± .5	TITLE: <b>80mm ID MANDREL, METRIC</b>				
0.XX = ± .010	0.XX = ± .25					
0.XXX = ± .005	0.XXX = ± .125					
WEIGHT		SIZE	DATE DRAWN	PART NO. <b>80M-M</b>	SCALE	REV
DRAWN BY	Michelle Neal	<b>B</b>	04/28/2015	MOD NO.	1:2	-01
DO NOT SCALE DRAWING		MATERIAL: 3" Sch. 40, STAINLESS STEEL			FINISH:	SHEET 1 OF 1