

REVISIONS			
REV.	DESCRIPTION	DATE	APPROVED
A	ADDED NOTE	3/2/2016	DC/MN

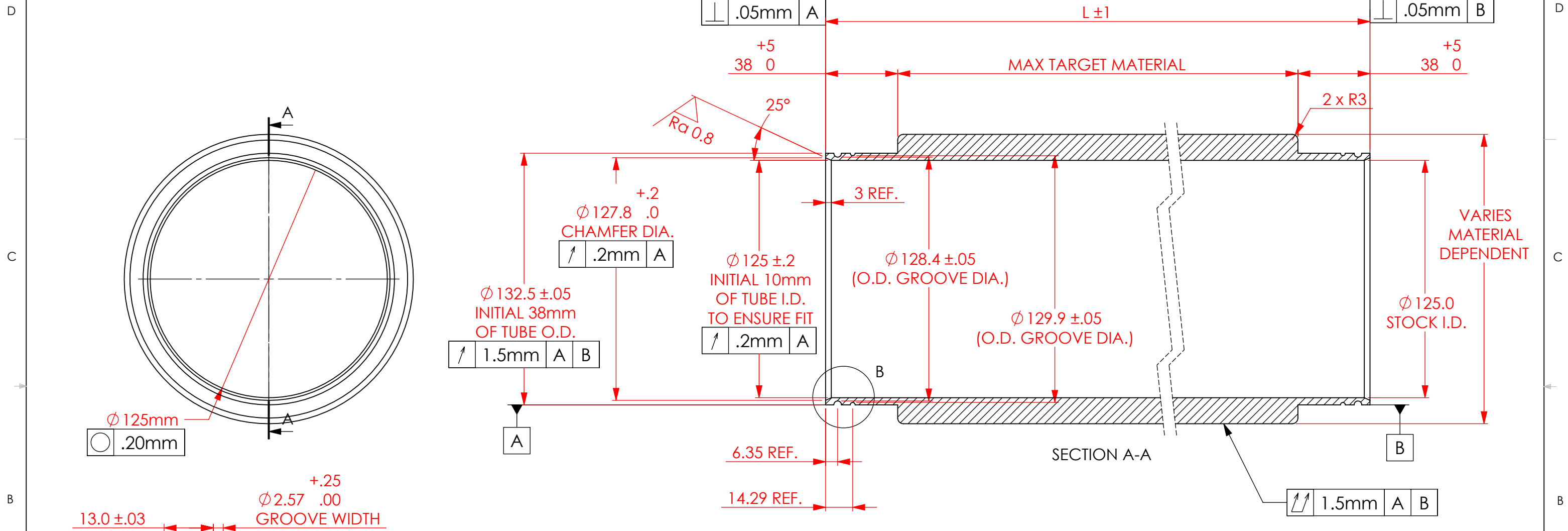

NOTE: DIMENSIONS ARE TYPICAL ON BOTH ENDS OF THE PART. FOR OUT OF ROUND TUBES, ENDS MUST BE BORED TO DIMENSION SHOWN.

- NOTES:**
- BREAK AND DEBURR ALL EDGES .25mm MAX.
 - CLEAN PART FOR USE IN A VACUUM ENVIRONMENT.
 - PACKAGE PART TO PROTECT FROM DAMAGE AND TO ENSURE CLEANLINESS.

4. THIS MONOLITHIC TARGET DESIGN MAY NOT SUPPORT ALL TARGET MATERIALS. CONSULT SCI WITH ANY QUESTIONS.

UNLESS OTHERWISE SPECIFIED:	
BREAK ALL CORNERS .015 Typ.	
ALL MACHINED SURFACES TO BE $\sqrt{63}$	
IMPERIAL	METRIC
X = ± .030	X = ± 1
0.X = ± .015	0.X = ± .5
0.XX = ± .010	0.XX = ± .25
0.XXX = ± .005	0.XXX = ± .125
DRAWN BY Michelle Neal	
DO NOT SCALE DRAWING	

SPUTTERING COMPONENTS, INC.
375 Alexander Dr. SW, Owatonna, MN 55060

TITLE: **QRM TARGET FOR CANTILEVER**

SIZE B	DATE DRAWN	PART NO. SCQTC	SCALE 1:2	REV A
MATERIAL: VARIES		MOD NO.	FINISH:	
SHEET 1 OF 1				